

Intelligent Industrial Safety Solutions

- Physical Partitioning
- Interlock Protection
- Access Control
- Safety Alert
- Cable Management
- Impact Protection



Smart Industrial Safety Expert

CATALOGUE

About Us

About Us	01
----------------	----

Solutions

Partitioning Solutions	02
Interlock Protection Solutions	04
Access Control Solutions	06
Safety Alert Solutions	08
Cable Management Solutions	10
Impact Protection Solutions	12

Service Introduction

Pre-sales Service	14
Packaging and Delivery	15
After-sales Service	15

About Us

Ningbo Vichnet Technology Co., Ltd was established in 2006. We are a national high-tech enterprise committed to the development, manufacturing and sales of smart industrial safety systems.

We provide partitioning solutions, machine guarding solutions, access management solutions, cable management solutions and impact protection solutions for our customers. We have obtained ISO9001, ISO14001, ISO45001, CE, UL, CUL, E90 certifications. We have also participated in the formulation of a number of national and group standards for warehouse logistics, food machinery and telecommunication engineering.

As a high-tech enterprise, Vichnet Technology understands that technological innovation is the lifeblood of a company. In 2018, Vichnet established its own new research and development center. Over the past three years, Vichnet has focused on developing new products that apply information technologies such as artificial intelligence and the Internet of Things in the field of safety production.

Partitioning Solutions

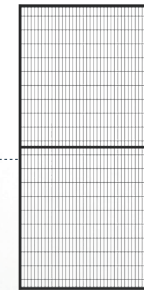

Fence panel

Different fence panels can be used in combination.

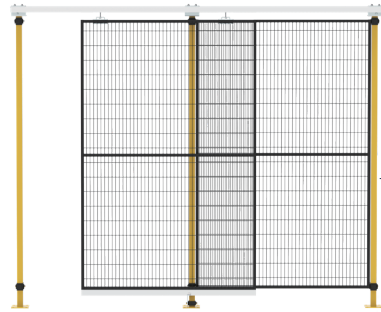
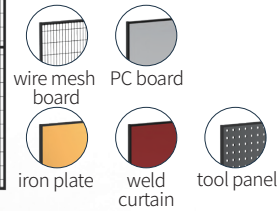

Sliding door with guide rail

Sliding door with a guide rail that allows panels to move horizontally. Both single and double open options are available.

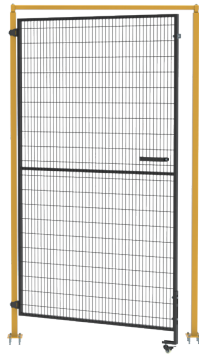
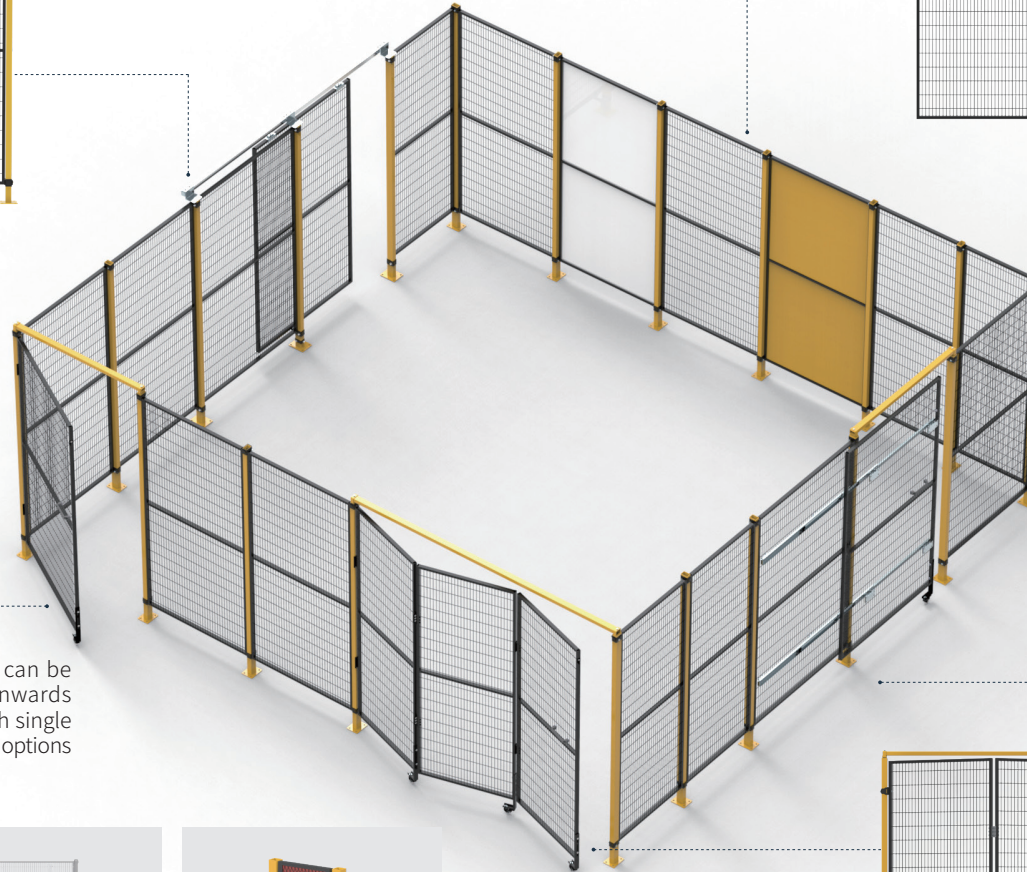

Hinge door

Hinge door that can be fitted to swing inwards or outwards. Both single and double open options are available.

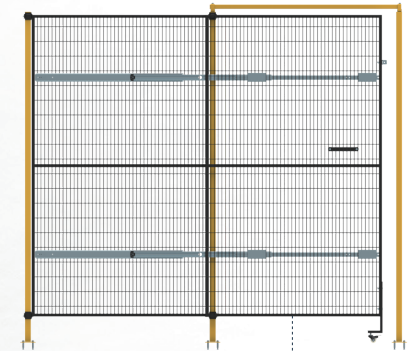

Sliding door

Sliding door that can be moved left and right. Both single and double open options are available.

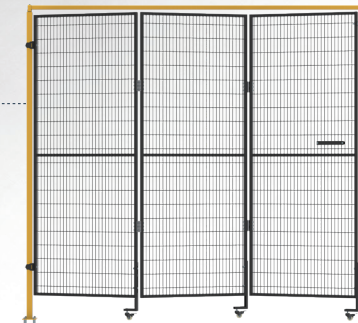

Folding door

Folding door that opens door panels to one side.

Other product series

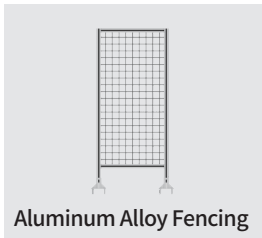

Aluminum Alloy Fencing



Stainless Steel Fencing



NAAMS Fencing

Interlock Protection Solutions



Alarm lamp

Lamp that provides visual signals indicating system status.

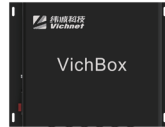

Vichbox

Vichbox contains pre-programmed interlock control systems, lowering the technical skills required of installation personnel.



Magnetic safety switch

Safety switch that provides interlock functions compliant with ISO 13849-1. Can reach performance level e.

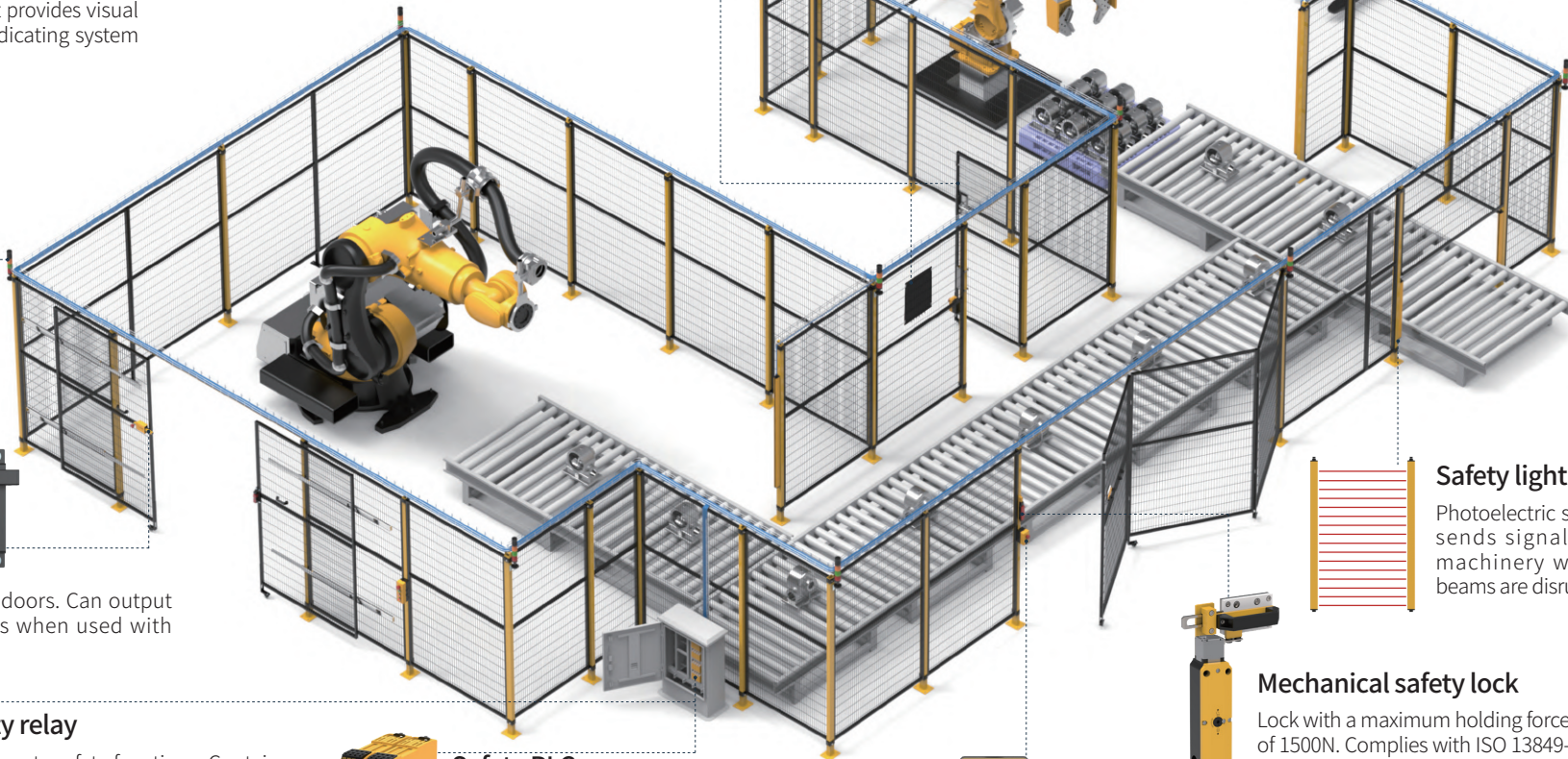

Bolt lock (Type B)

Installed on fence doors. Can output lock status signals when used with safety switches.



Safety light curtain

Photoelectric sensor that sends signals to stop machinery when light beams are disrupted.



Safety relay

Implements safety functions. Contains multiple relays and circuits to overcome the shortcomings of each individual component. Can achieve low error and failure rates.

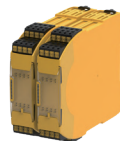

Safety PLC

Programmable logic controller that ensures safe system responses even when individual system components fails.



Mechanical safety lock

Lock with a maximum holding force of 1500N. Complies with ISO 13849-1. Safety interlock function capable of reaching performance level e.



Button switch

Manual control device used to control contactors, relays, electromagnetic starters, etc.

Access Control Solutions

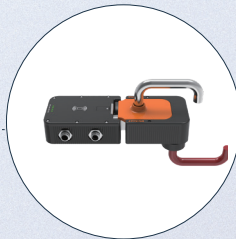

Smart LOTO safety lock

An intelligent lock that uses RFID card swiping to authorize entry. Its lockout/tagout programming reduces the risk of personnel being trapped in restricted areas. With the embedded CAT1 wireless communication module, all event logs can be exported, and the system can be upgraded remotely.

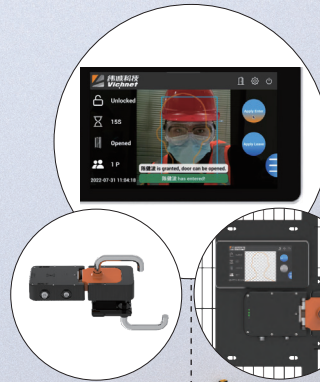

Facial recognition module

Used with our smart LOTO safety locks to authorize entry through facial recognition. Works well even when personal protective equipment covers part of the face. Facial ID registration can be completed both locally and through cloud platforms.

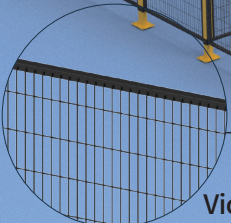
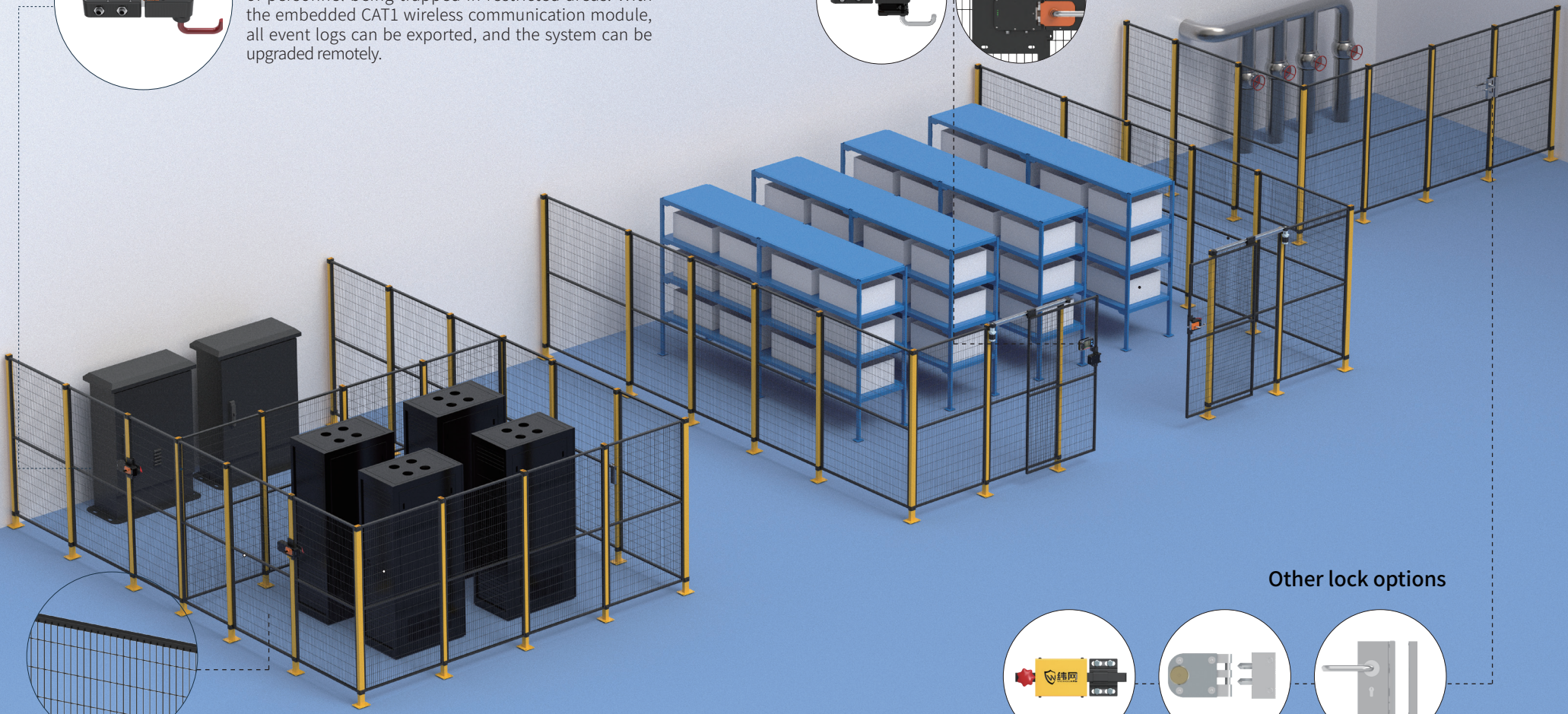

Vichnet fence

Spacing designed to prevent climbing and unauthorized access.

Other lock options



For single sliding door and double door

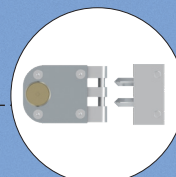

For single sliding door and double door

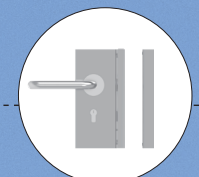

For single hinge doors

Safety Alert Solutions



AI system for dangerous area personnel detection

Uses AI visual recognition to determine whether a person or part of a body has entered a pre-defined dangerous area, supports edge interactions and warning signal output.

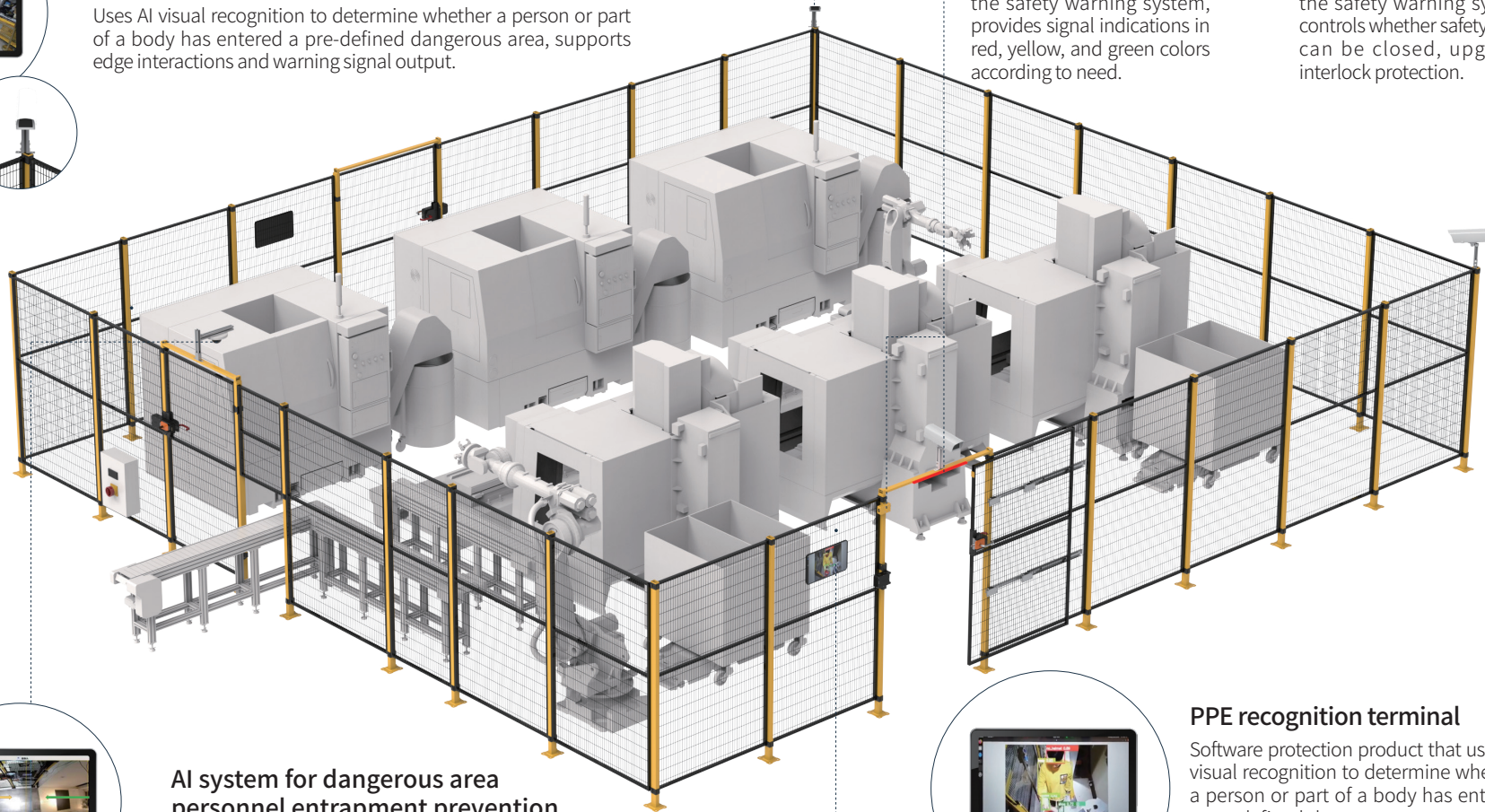
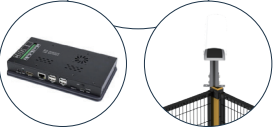

AI system for dangerous area personnel entrapment prevention

Prevents personnel entrapment in the case of LOTO failure. Accurately detects the number of people entering and exiting a doorway to calculate the number of people remaining in the controlled area, capable of identifying tailgating and parallel movement.

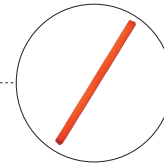

Warning light bar

Executing mechanism of the safety warning system, provides signal indications in red, yellow, and green colors according to need.

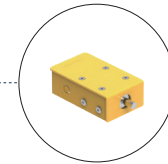

Electric push rod

Executing mechanism of the safety warning system, controls whether safety doors can be closed, upgrades interlock protection.

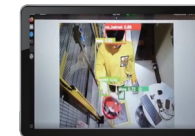

PPE recognition terminal

Software protection product that uses AI visual recognition to determine whether a person or part of a body has entered a pre-defined dangerous area, supports edge interactions and warning signal output.

Cable Management Solutions

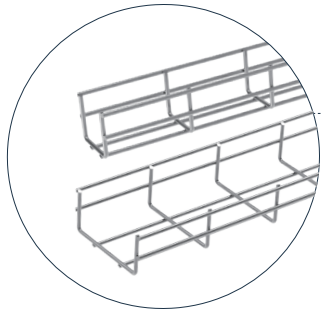

Wire mesh cable tray

Provides point-to-point pathways that support and protect cables. 50x50mm and 50x100mm trays are most commonly used.

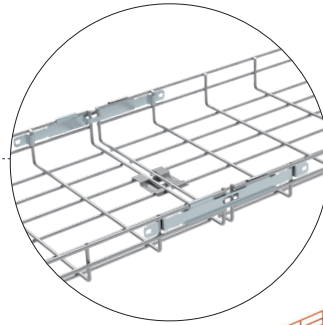

Fast connectors

Connectors designed to allow fast and easy installation.

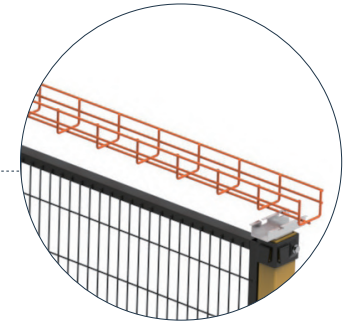

Top routing

Routes cables on the top of the fence.

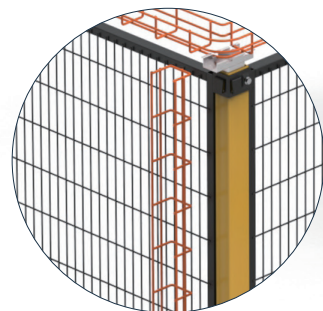

Vertical downward cabling

Routes cables downwards.

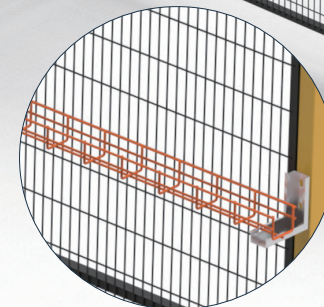

Side routing

Routes cables on the side of the fence.

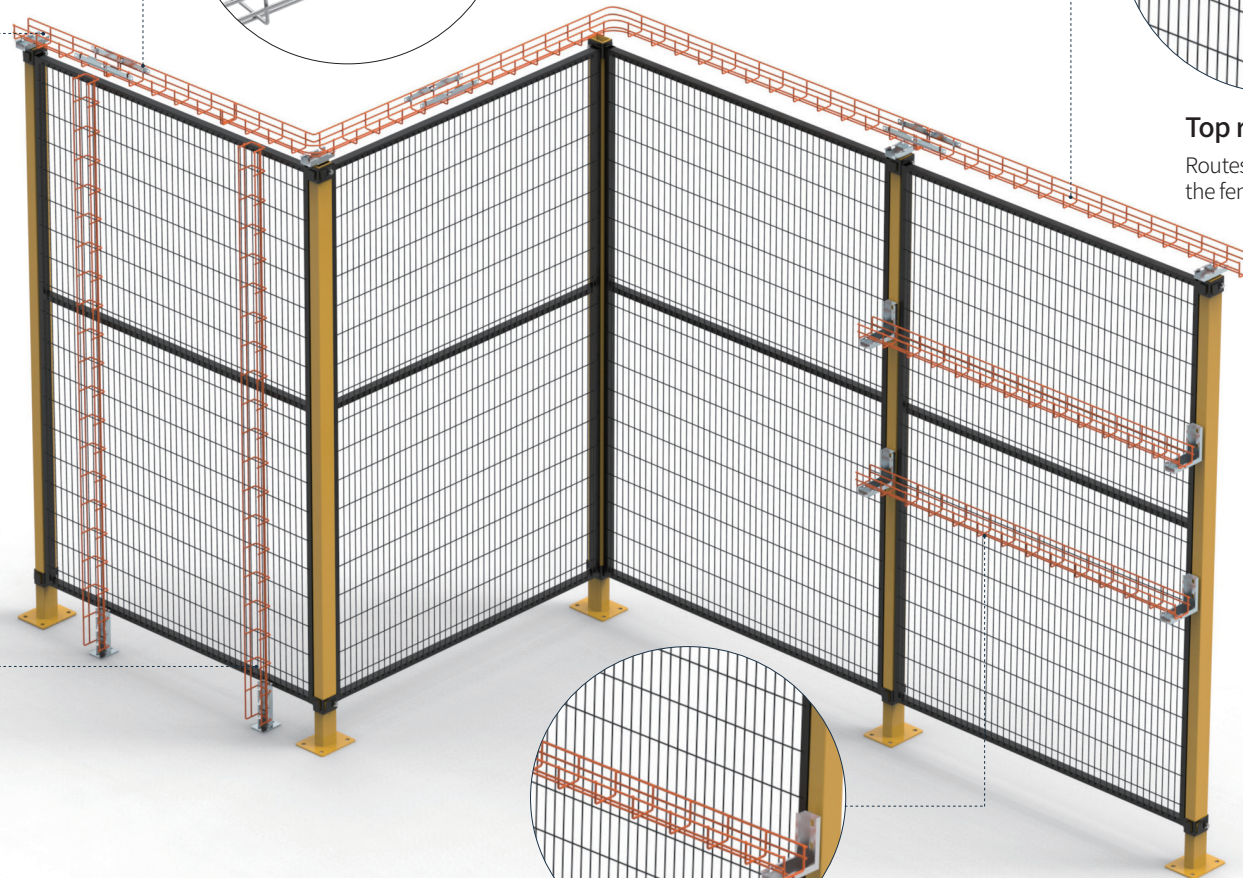

Impact Protection Solutions

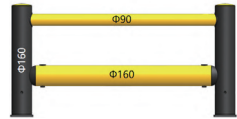

M barriers
Economical impact protection solution for logistics channels.

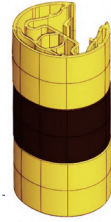

Flexible plastic foot guard
Protects storage rack columns.

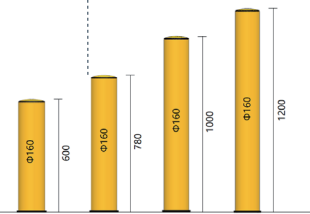
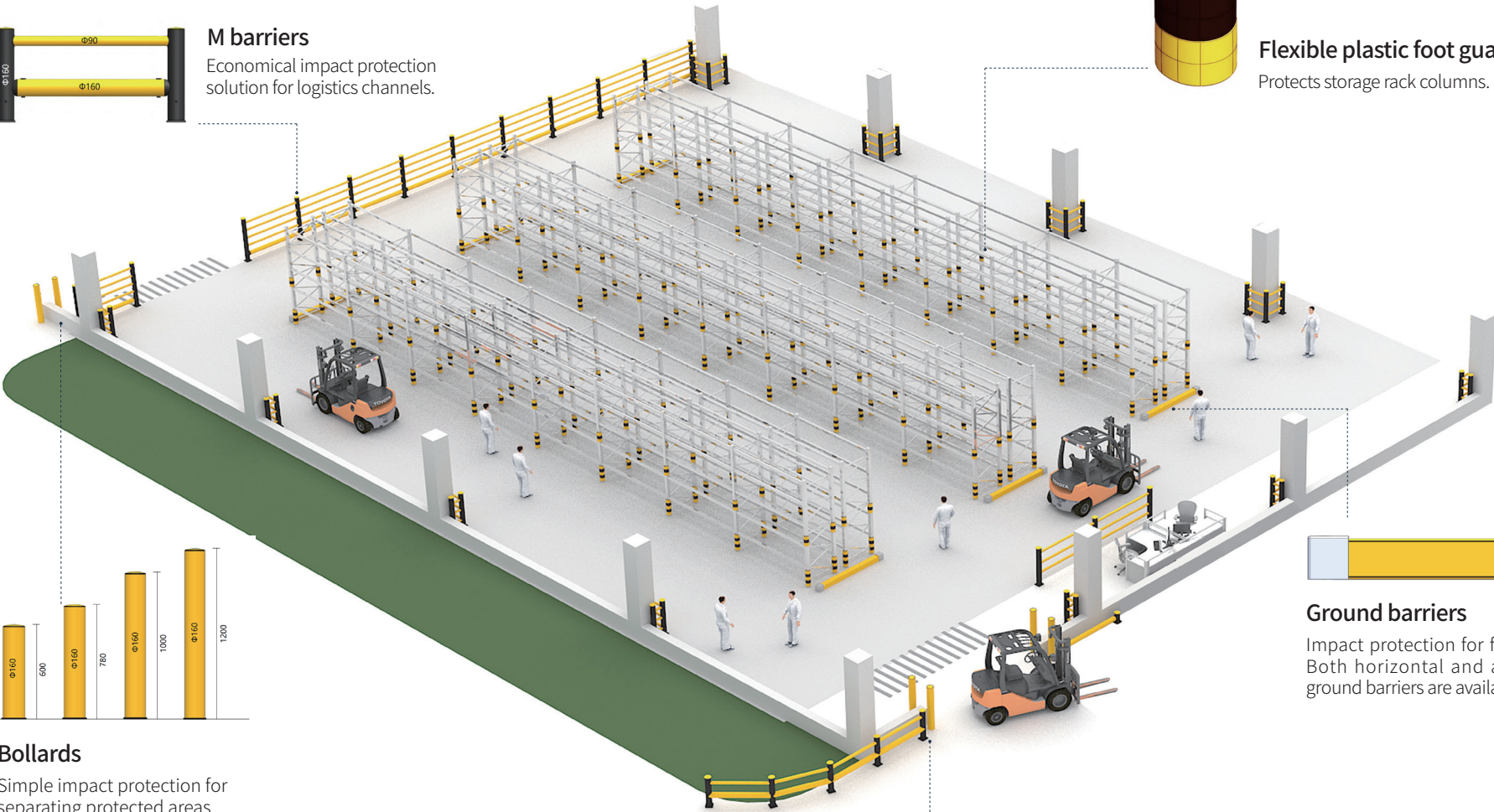

Bollards
Simple impact protection for separating protected areas.



Ground barriers
Impact protection for forklifts. Both horizontal and arcuate ground barriers are available.

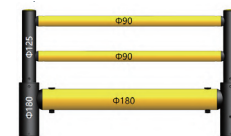

H barriers
High performance impact protection solution for logistics channels.



Pre-sales Service

On-site Measuring Service



Professional Safety Fence Design

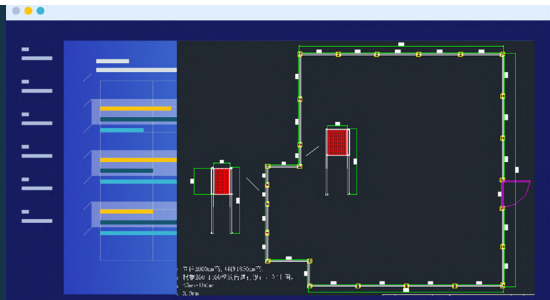

Professional Safety Control Design

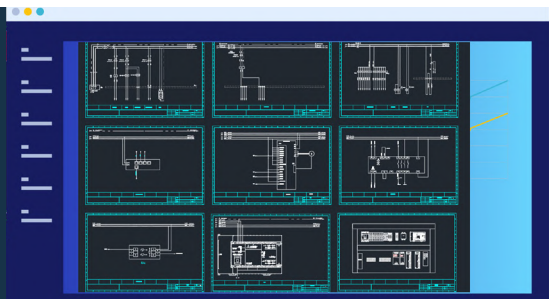

Packaging and Delivery



After-sales Service

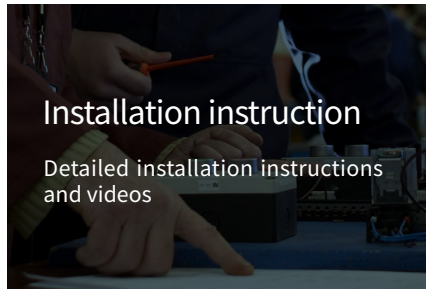
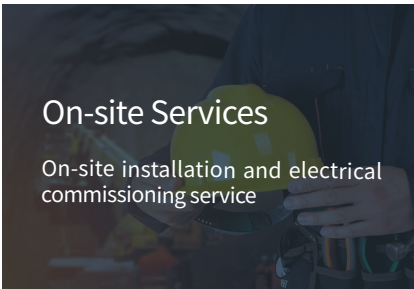



NINGBO VICHNET TECHNOLOGY CO., LTD

Tel: +86 13094835367

Fax: 0574-87911327

Website: www.vichnet.com

Email: exporter@vichnet.cn

Office Add: 10F Building 7, Smart Park, Hi-tech Zone, Ningbo City, China

Factory Add: No.329 Jiangbin Road, Beilun District, Ningbo City, China